

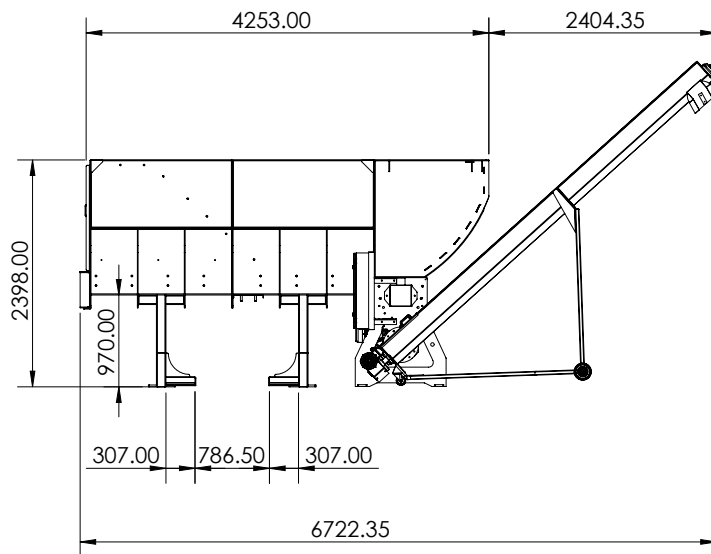

Technical specifications

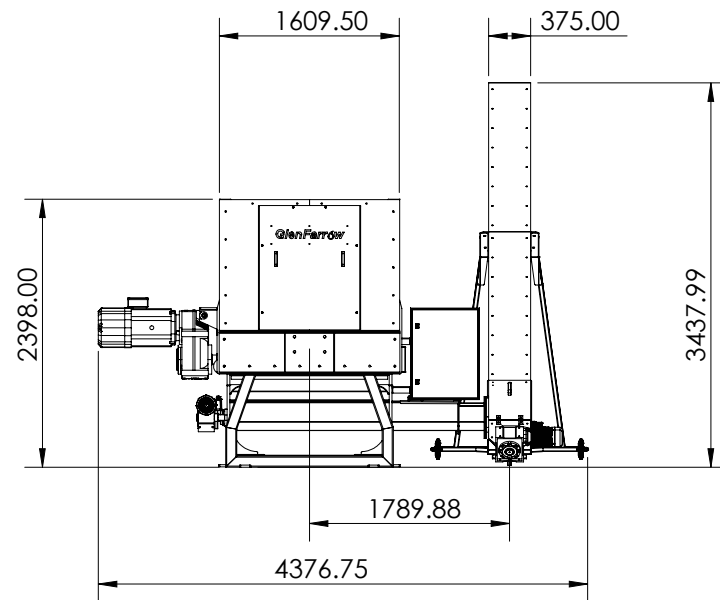

GFPC1400 auto

- Power: 22kW (+5.5kW)*
- Rotor: 152mm - 168mm diameter options
- Rotor with teeth: 270mm diameter
- Number of teeth: 29
- Rotor speed at 50Hz: 59rpm
- Noise level: 89dB
- Ram travel: 1300mm
- Chipping width: 1345mm
- Rotary screw compressor: 5.5kW
- Weight (excluding incline auger): 4450kg
- Weight (including incline auger): 4800kg
- Weight (including incline auger and compressor): 5050kg

*Compressor option adds 5.5kW

General overview

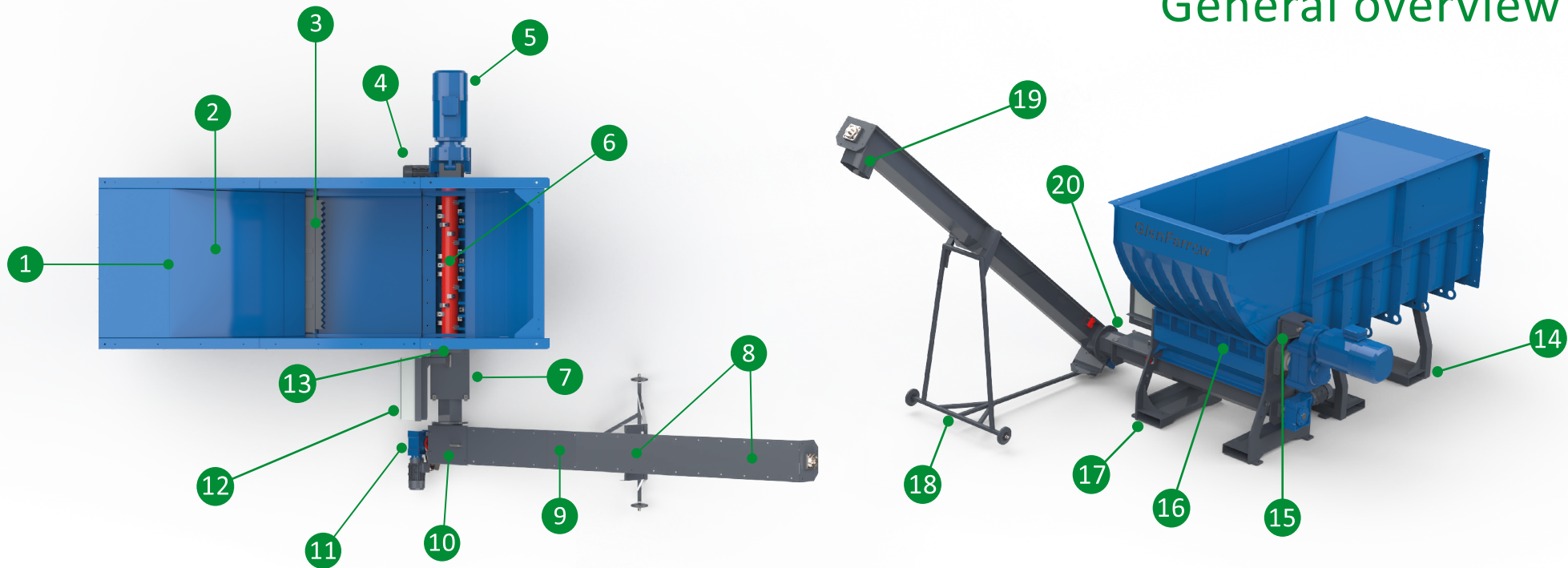

- ① Infeed chute
- ② 200mm pneumatic ram
- ③ Moving cassette
- ④ Cross auger motor and gearbox
- ⑤ Main chipper motor
- ⑥ Main chipper shaft
- ⑦ Cross auger inspection hatch

- ⑧ Auger cover plates
- ⑨ Incline auger
- ⑩ Incline auger inspection hatch
- ⑪ Incline auger motor and gearbox
- ⑫ Control panel
- ⑬ Bearing cover
- ⑭ Forklift pocket and leg

- ⑮ Main motor torque restraint fixing point
- ⑯ Cassette
- ⑰ Forklift pocket and leg
- ⑱ Support for incline auger
- ⑲ Incline auger chip output spout
- ⑳ Adjustable flange mount

Key features

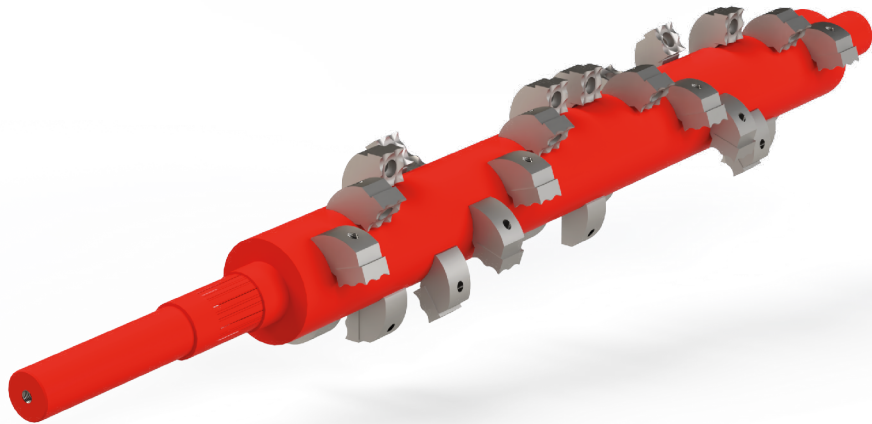
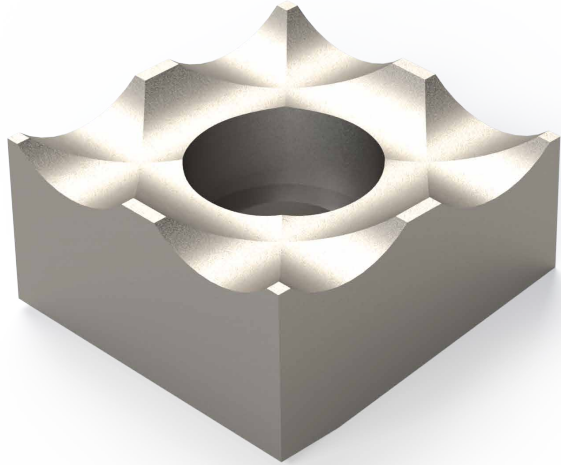

Robust cutting system

- Large 270mm diameter rotor with teeth
- Large screen area split into two sections for easy removal and changing
- Different screens available for different chip requirements
- Square teeth that can be rotated four times for a prolonged service life

Different teeth options

- We offer various teeth sizes and shapes for different types of wood material
- Bespoke teeth options are also available and are customisable to meet the customer's cutting requirements

Key features

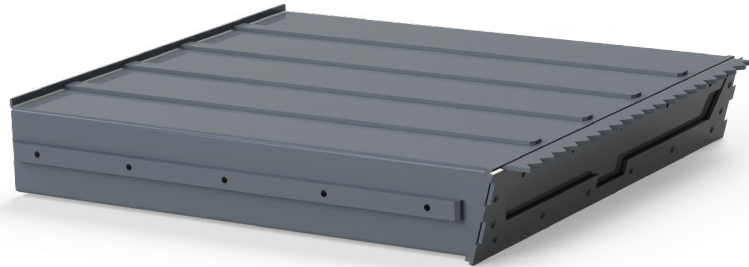

Powerful pneumatic infeed

- Advanced technology allows for constant monitoring of load onto the rotor
- Pneumatic ram stops and starts according to motor load to ensure maximum throughput of material
- Optional on-board screw compressor for continuous operation
- Serrated edge for aggressive material movement

Easy removal of wood chip

- Incline auger is included with every auto-chipper for fast and effective removal of wood chip
- Adjustable angles to suit any application



Key features



Hassle free system

- High quality gearbox and 3 phase motor
- System automatically reverses when overloaded
- Straightforward controls and hour counter for servicing intervals
- Automatic feed control via logic controller and pneumatics

Easy maintenance

- Easy access to the cutting system via hatches with intergrated safety switches
- Fast turning and changing of teeth
- Easy to remove non-shreddable items from the system

Benefits of GlenFarrow

Customisable chippers



Our auto-chipper is fully customisable upon request. From auger lengths to screen sizes and bespoke teeth, we work closely with our customers to tailor our products to their needs.

Turnkey biomass solutions



With over 2000 GlenFarrow biomass boilers installed in the UK, we are experts in providing our customers with full turnkey biomass solutions for their heating.

Book a test trial



We understand the importance of investing in a quality product. That's why we invite all customers to book a test trial of our chipper using their own material.

National network of engineers



We have a national network of in-house service engineers so you can be rest assured that GlenFarrow will be there for you wherever you are based in the UK.



Find us:

Glen Farrow UK Ltd
Glendum Close
Pinchbeck
Spalding
Lincolnshire
PE11 3DQ

What 3 words: [///ample.rectangular.transmits](http://ample.rectangular.transmits)

01775 722327
info@glenfarrow.co.uk
glenfarrow.co.uk

